

Maintenance & Adding oil for Hydraulic Riveter:

1. Disconnect air hose.
2. **Use an adjustable or combination wrench (not included) to take apart head as in fig. 1 .**
3. Use the spanner to open the bottom cover as fig. 2 .
4. Remove the piston of the cylinder as fig. 3 .

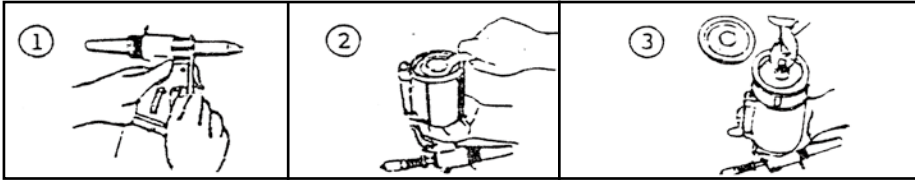

5. Clean the inside of the cylinder and the frame body.
6. Full the lubricate oil as fig. 4 .
7. Clean the stem of piston, apply grease to the inner wall of cylinder and the O-ring as fig. 5 .

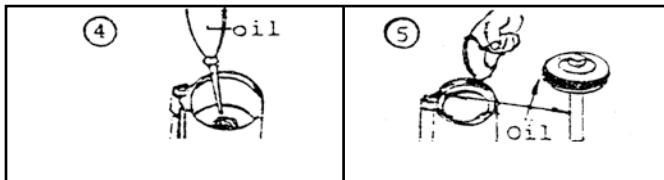

8. Reassemble the riveter by following the disassembly procedure in reverse.

Clean & Maintenance for the Head of Riveter

1. Disconnect air hose.
2. Use spanner to take apart the head as fig. 1 .
3. Use spanner to take apart the part as fig. 2 .
4. Clean all the part and inside of the head as fig. 3 .

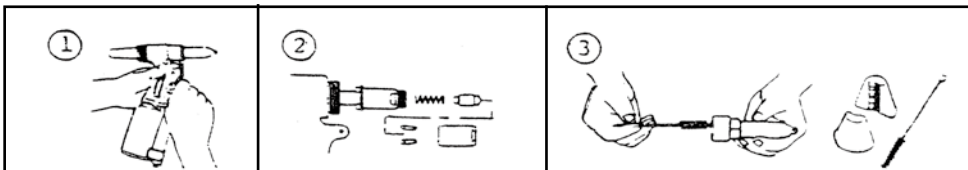

5. Apply lubricate oil as fig. 4 .
6. Check the length as fig. 5 .

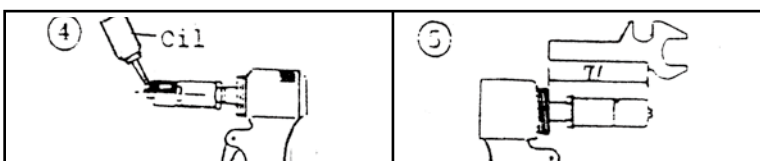

7. Reassemble the Head of Riveter by following the disassembly procedure in reverse.

3/16" AIR RIVETER

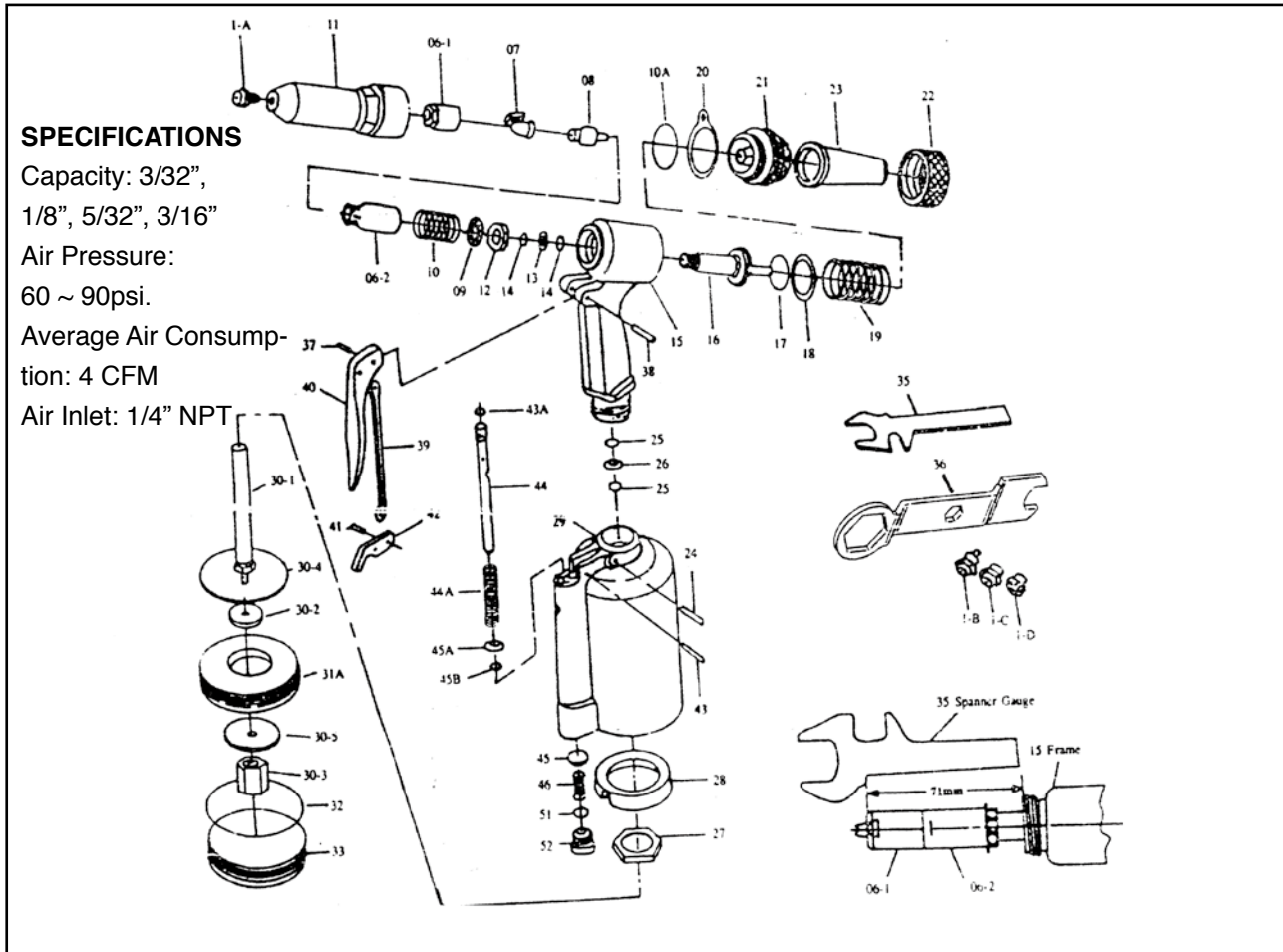

PART NO.	DESCRIPTION	PART NO	DESCRIPTION
1A	Nosepiece (3/16")	27	Frame Lock Nut
1B	Nosepiece (5/32")	28	Rubber Cushion
1C	Nosepiece (1/8")	29	Air Cylinder
1D	Nosepiece (3/32")	30-1	Air Piston Stem
06-1	Jaw Case Front Tart (3/32", 1/8", 5/32")	30-2	Air Piston Al
		30-3	Air Piston Lock Nut
06-2	Jaw Case End Tart	30-4	Big Iron Plate
07	Jaw	30-5	Small Iron Plate
08	Jaw Pusher	31A	Air Piston Ring
09	Case Washer Ring	32	Cylinder O Ring 67.94x2.62
10	Jaw Pusher Sping	33	Cylinder Cap
10A	Frame Cap O Ring 27x2	35	Spanner Gague
11	Frame Head	36	Spanner
12	Case Lock Nut	37	Trigger Pin
13	Back Up Ring	38	Connector
14	Back Up O Ring p12	39	Trigger Rod
15	Frame	40	Trigger
16	Oil Piston	41	Connector
17	Oil Piston O Ring p22A	42	Trigger Lever
18	Back Up Ring	43	Lever Pin
19	Return Spring	43A	Valve Pusher O Ring p7
20	Hanging Clip	44	Valve Pusher
21	Frame Cap	44A	Valve Spring
24	Setting Screw Pin	45	Valve
25	Back Up O Ring 12	45A	Valve Collar
26	Bakc Up Ring	45B	Collar O Ring p5
22	Frame Cap Nut	46	Valve Spring
23	Safety Cap	51	Valve Cap O Ring p11
		52	Valve Cap